

TNet DESIGN

McQ designed TNet to optimize sensor communications. Sensor target detections and images must be delivered to the user fast and very reliably. Sensors and communication units also need to receive command and control information from the user as well as message acknowledgement for guaranteed delivery. The TNet design insures inbound target detections messages are delivered instantaneously through the Repeater chain and outbound messages are delivered in a timely manner. Because the sensors and Repeaters are battery powered, very low power consumption has been designed into the network. The TNet design uses a Mesh Ad Hoc Network architecture. The Repeaters and Base Stations keep track of every component they can communicate with, "neighbors," and route message traffic automatically to all units. TNet is a very flexible and efficient sensor network solution.

McQ Terrestrial Network (TNet)

Connecting Your Sensors to the World

McQ developed a terrestrial RF wireless network designed specifically for unattended ground sensor applications. This network relays the sensor information over terrain that precludes an RF line of sight path from the sensor to the user. TNet is a self forming RF network that makes it easy for the user to quickly set up in the field. TNet is designed to maintain very low power consumption of the battery powered sensors and repeaters.

- Sensor Information Relay Easily Set Up in the Field
- Self Forming and Self Healing Mesh Ad Hoc Network
- Automatic Recognition and Reporting of "Neighbor" Sensor of Repeater Units
- Guaranteed Delivery of Messages
- Very Low Power Consumption with Solar Recharging Options
- Long RF Link Distances with Multiple Repeater Architecture
- Very Fast Delivery of Target Alarms and Images
- Internet Protocol (IP) Network Connectivity
- Outdoor Rugged Environment and Rack Mount Units



TNet Specifications

TNet OPERATION

TNet allows a user to quickly set up the sensor network in the field. The user can select one of ten network channels for each sensor network. Each TNet unit can act as a Repeater or as a Base Station. One unit is configured as the Base Station and one or more units are configured as Repeaters to reach from the sensors to the Base Station. The TNet units recognize other units on the network channel, automatically route the message traffic to the Base Station, and manage the command and control messages so they are delivered to the intended recipient. The Base Station unit connects via Ethernet to any IP network for distribution to the map based sensor system user interface.

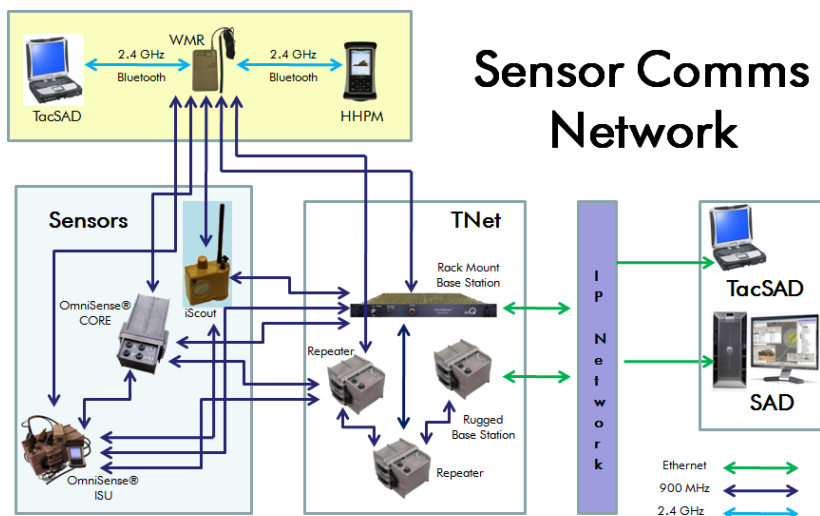

Rugged Repeater/Base Station Unit:

- Size: 8 x 6 x 8 (One BA Series Battery) / 8 x 6 x 14 (Three BA Series Batteries)
- Weight: 9 Lbs (One BA Series Battery) / 16 Lbs (Three BA Series Batteries)
- Power: 10 to 18 Volt DC
- Channels: 10 Separate Channels
- Input/Output: Ethernet TCP/IP Serial Connector, External Power Connector, RS-232 Serial Connector
- GPS: Internal GPS Receiver and External Antenna
- Tamper: Selectable Tamper Report Configurations
- Configuration: Configured Over the Network or Locally

Rack Mount Repeater/Base Station Unit:

- Size: 19 Inch Rack Mount x 1 3/4 Height
- Weight: 5 Lbs
- Power: 120/240 AC, 50/60 Hertz, or 12 Volt DC
- Channels: 10 Separate Channels
- Input/Output: Ethernet TCP/IP Serial Connector, RS-232 Serial Connector
- GPS: Internal GPS Receiver and External Antenna
- Configuration: Configured Over the Network or Locally

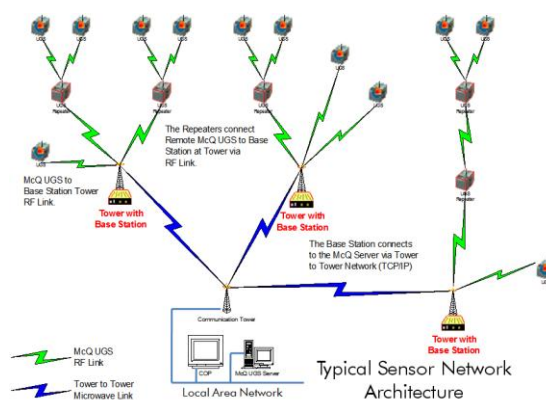

For more information on any of our products or services please visit us on the Web at: www.mcqinc.com

February 2012 McQ Inc.

1551 Forbes Street
Fredericksburg, VA
22405-1603 USA

T: 540.373.2374
www.mcqinc.com

